

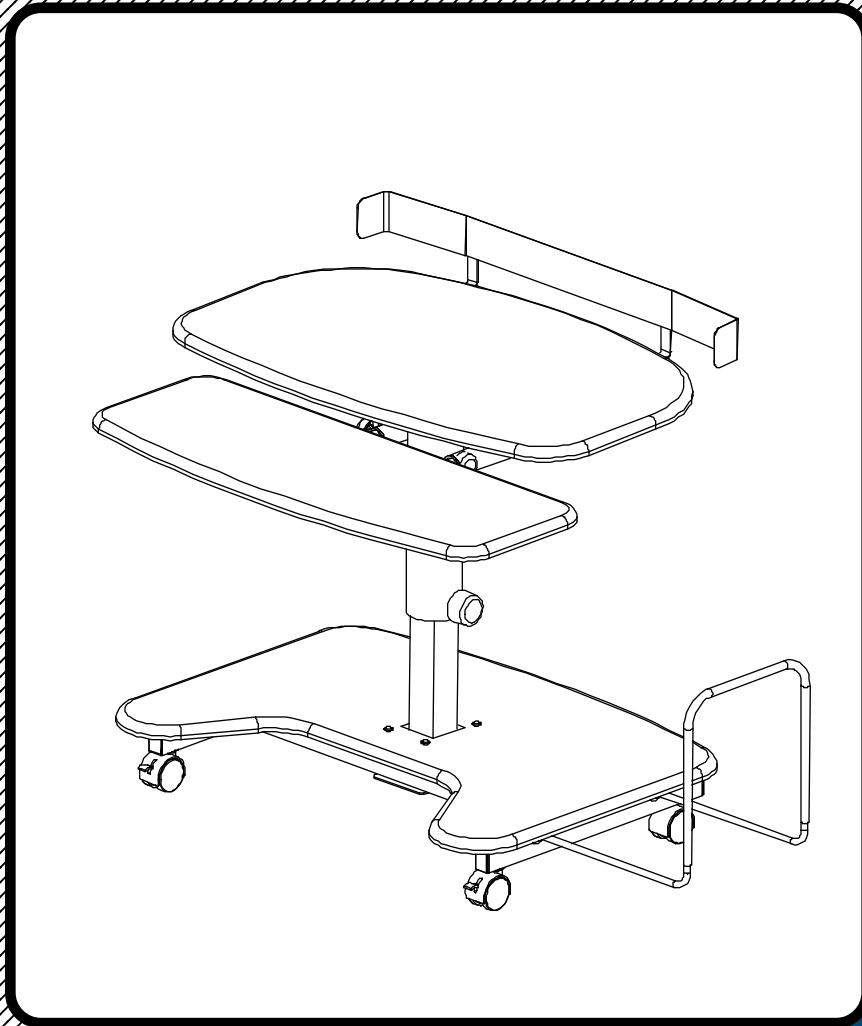

# #45972 HI-LO-3











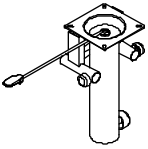

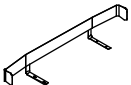



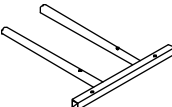



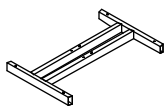

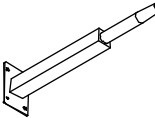
Adjustable Pneumatic Workstation

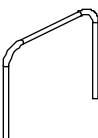

## Assembly Instructions

# #45972 Hi-Lo-3

## Adjustable Pneumatic Workstation

Part	Drawing	Description	Qty	Part	Drawing	Description	Qty
P-1		Top Platform	1 EA	<b>Hardware List</b>			
P-2		Top Support	1 EA	A		Flat Head Screw	10 EA
P-3		Security Rail	1 EA	A1		1-1/4" Flat Head Screw	4 EA
P-4		Keyboard Platform	1 EA	B		2-3/8" Flat Head Screw	8 EA
P-5		Keyboard Slide	1 EA	C		Interior Threaded Post	4 EA
P-6		Bottom Shelf	1 EA	D		2" Locking Caster (for Front)	2 EA
P-7		Base Frame	1 EA	E		2" Caster (for Back)	2 EA
P-8		Cylinder Assembly	1 EA	F		Allen Wrench	1 EA
P-9		CPU Sleeve	1 EA	G		Adjustment Knob (factory installed)	1 EA
P-10		CPU Rod	2 EA	H		Caster Wrench	1 EA
P-11		Keyboard Slide Plate	1 EA	N		Flat Washer	4 EA
				P		Black Plastic Spacer	2 EA
				Q		Hex Nut	4 EA

# #45972 HI-LO-3 Assembly Diagram

**READ THROUGH INSTRUCTIONS FROM BEGINNING  
TO END BEFORE STARTING TO ASSEMBLE UNIT.**

## ***To Assemble:***

*Identify and Separate all the Parts and Hardware.*

1. Separate Pneumatic Cylinder Assembly into 2 pieces (P-2) and (P-8)
  - a.) Loosen Knob by turning counter clockwise 2-3 turns.
  - b.) Place Pneumatic Cylinder Assembly on the floor and lift Handle to actuate cylinder.
  - c.) When Cylinder is fully extended, lift Top Support (P-2) off Cylinder Assembly (P-8)

Pneumatic Cylinder Assembly

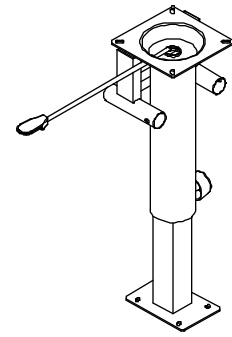

Pneumatic Cylinder  
Assembly

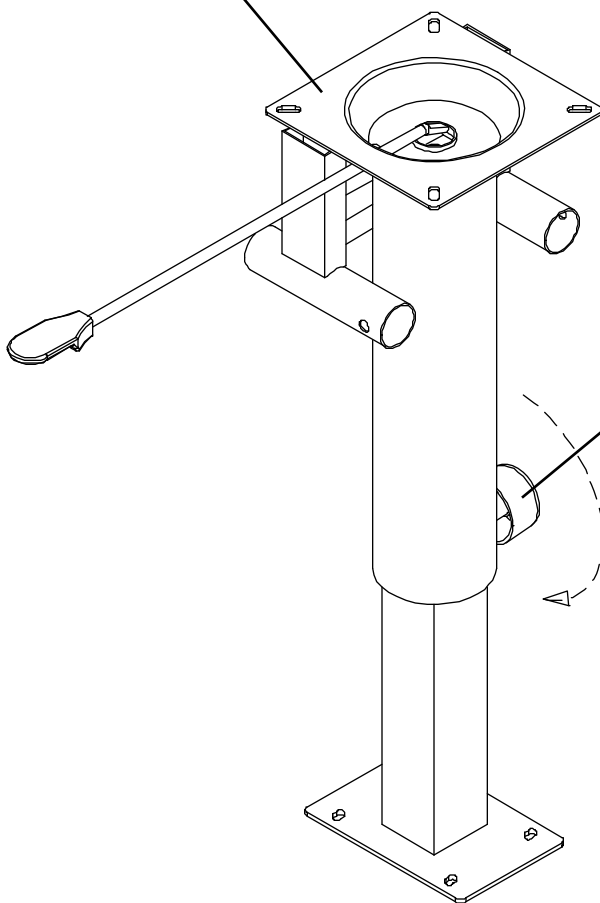

Loosen Knob by  
turning counter  
clockwise 2-3  
turns

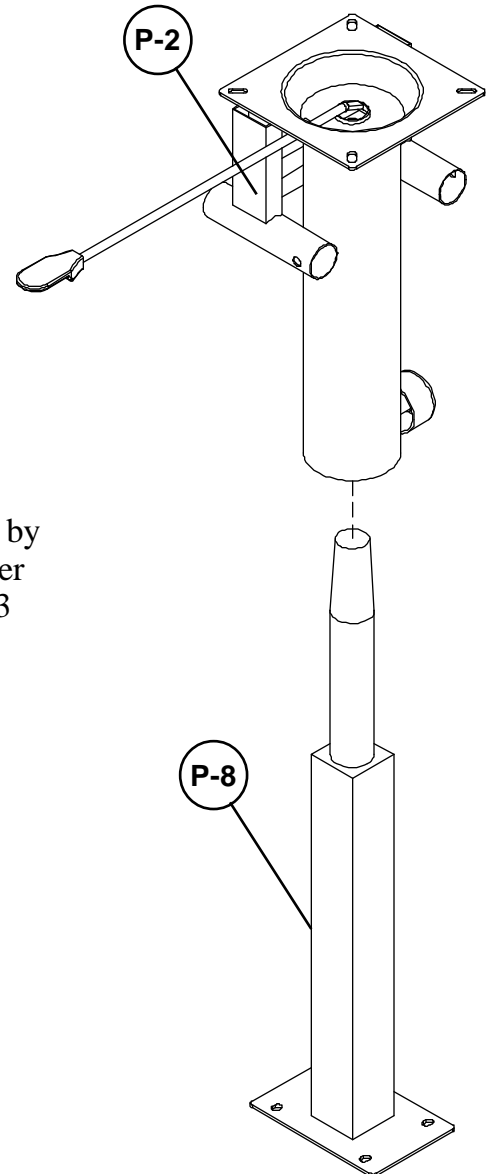

# #45972 HI-LO-3



Illustration # 1 - Base Assembly

- Place the Bottom Shelf (P-6) with the insert nuts facing up and attach Base frame (P-7) using 4 (2-3/8") Flat Head screws (B).

*(Do not tighten screws all the way)*

- Attach Cylinder Assembly (P-8) to the Base frame (P-7) and the Bottom Shelf (P-6) using 4 (2-3/8") Flat Head screws (B) and 4 Interior Threaded Posts (C) as shown in illustration # 1.

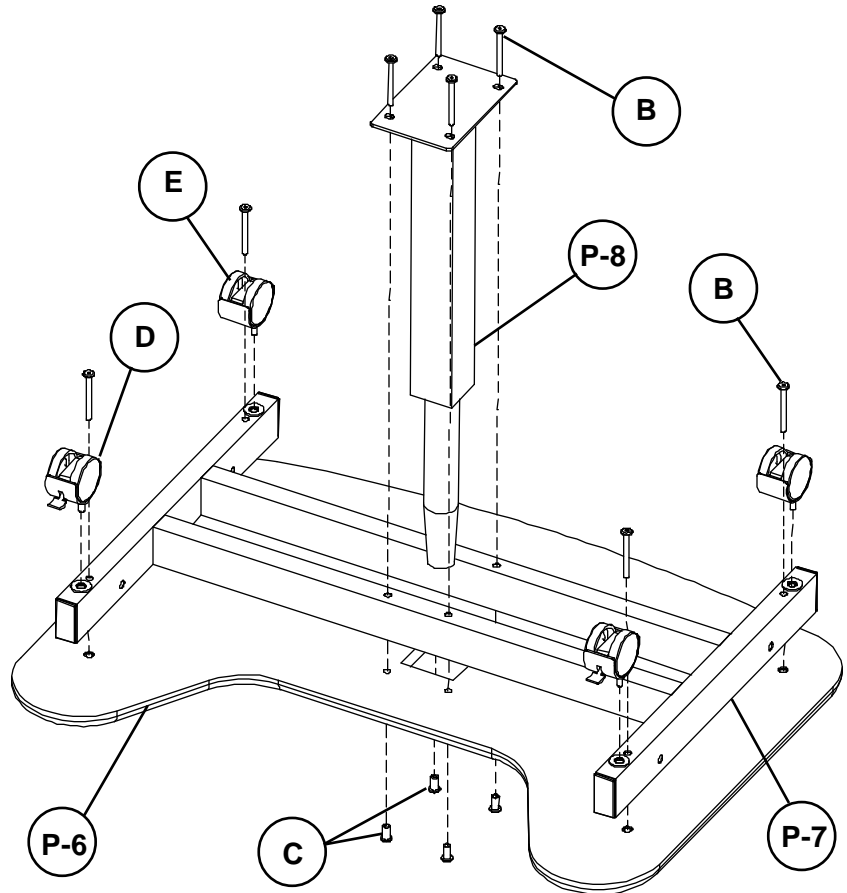
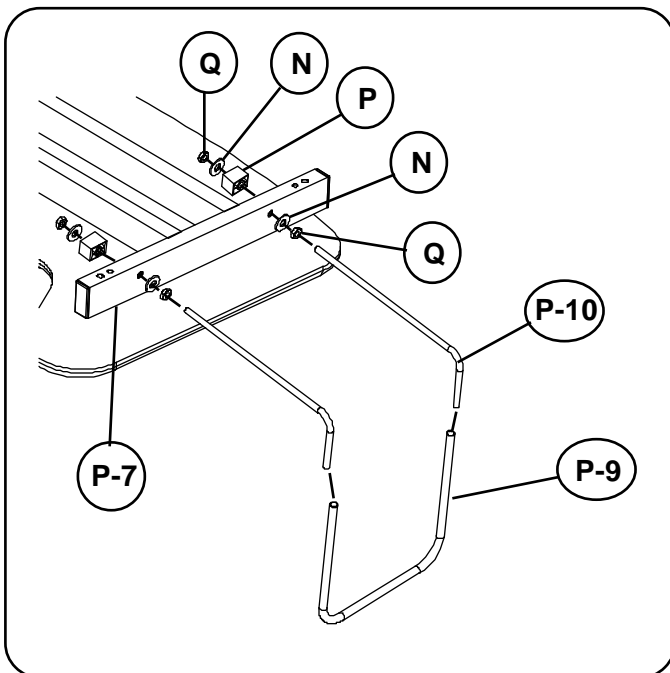
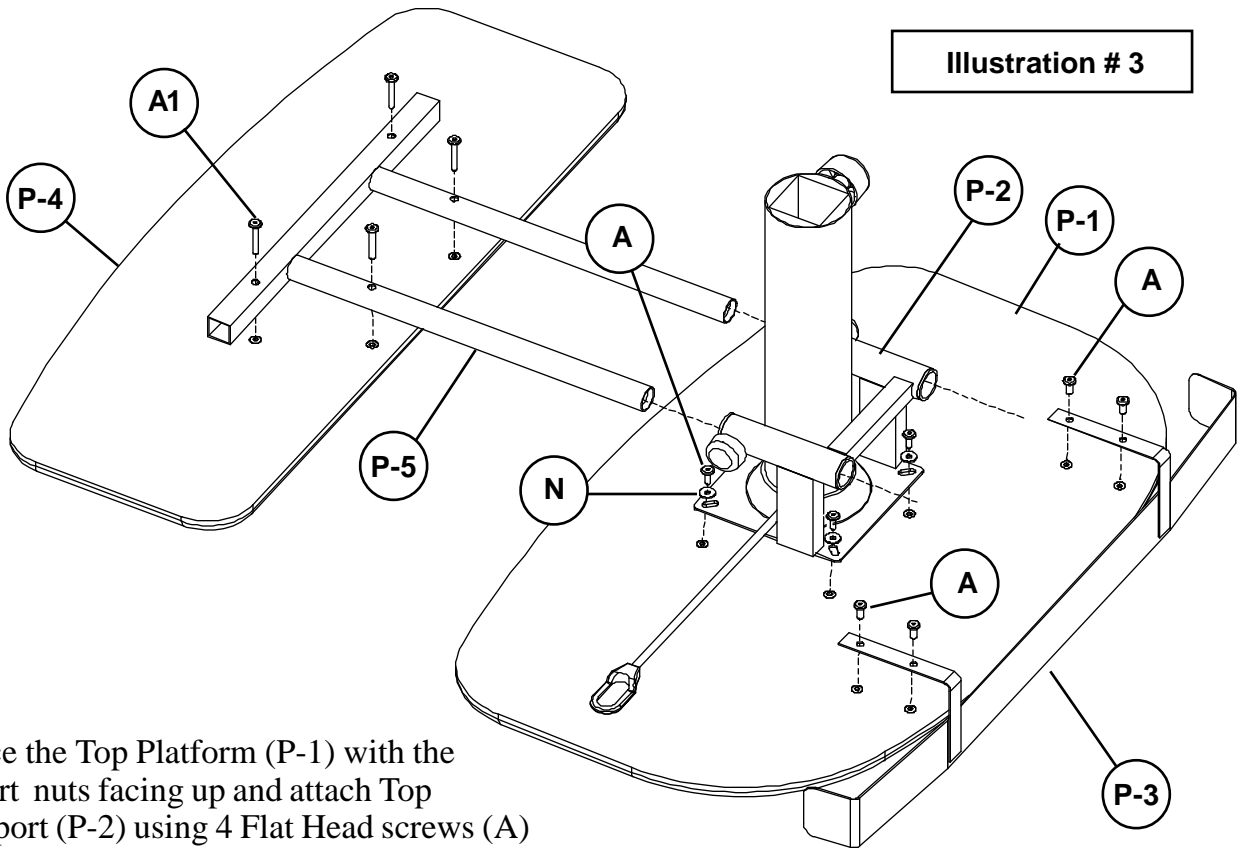

Illustration # 2



- Attach Casters to the Base Frame (P-7). 2 Locking casters (D) in the front and 2 Casters (E) in the back. Tighten Casters using Caster Wrench (H).
- Attach (2) each CPU Rods (P-10) to the Right side or Left side of the Base frame (P-7) as shown in illustration #2.
- Secure each CPU Rod (P-10) with (2) each Hex nuts (Q), (2) each Flat Washers (N), and (1) each Black Plastic Spacer (P).
- Slide CPU Sleeve (P-9) over ends of CPU Rods (P-10) as shown in illustration # 2.

Illustration # 3



8. Place the Top Platform (P-1) with the insert nuts facing up and attach Top Support (P-2) using 4 Flat Head screws (A) and 4 Flat Washers (N) as shown in illustration # 3.

9. Attach Security Rail (P-3) to Top Platform (P-1) using 4 Flat Head screws (A).

10. Place the Keyboard Platform (P-4) with the insert nuts facing up and attach Keyboard Slide (P-5) using 4 (1-3/8") Flat Head screws (A1) as shown in Illustration # 3.

11. Insert the Keyboard Slide (P-5) through the Top Support (P-2) and secure it by attaching Keyboard Slide Plate (P-11) with 2 Flat Head screw (A). [Illustration # 4].

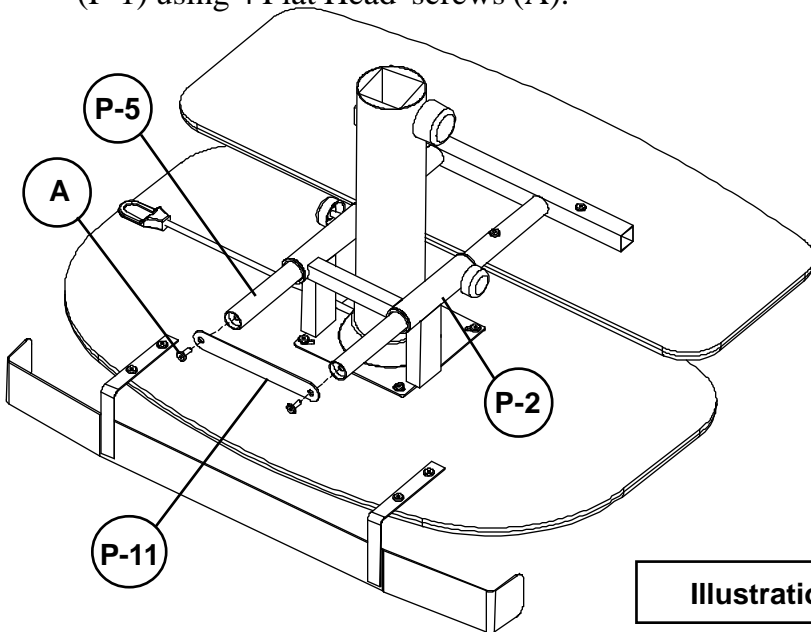

Illustration # 4

**Missing Parts or UPS Damaged Parts**

For Your Convenience you can  
EMAIL us at  
***[furniture@baltinc.com](mailto:furniture@baltinc.com)***  
24HOURS 7 DAYS A WEEK

Do not use unless all screws are tight. At least every six months, check all screws to be sure they are tight. If parts are missing, broken, damaged, or worn, stop use of the product until repairs are made by your dealer using factory authorized parts.

## Height Adjustment

To raise height of unit, loosen adjustment knob (G) and press handle on height adjustment bracket upward toward top. The pneumatic cylinder will begin lifting the unit, and you can release handle at the desired height. Secure unit at desired height by tightening adjustment knob (G).

To lower height of unit, loosen adjustment knob (G) and press handle on height adjustment bracket upward toward top. Press on center of Top Platform using body weight. Top Platform will lower and you can release handle at the desired height. Secure unit at desired height by tightening adjustment knob (G).

- Slide the Top Support (P-2) over the Cylinder Assembly (P-8) as shown in illustration #5. Be sure that rod locks into Top Support (P-2) for correct height adjustment. [See Detail-A.]

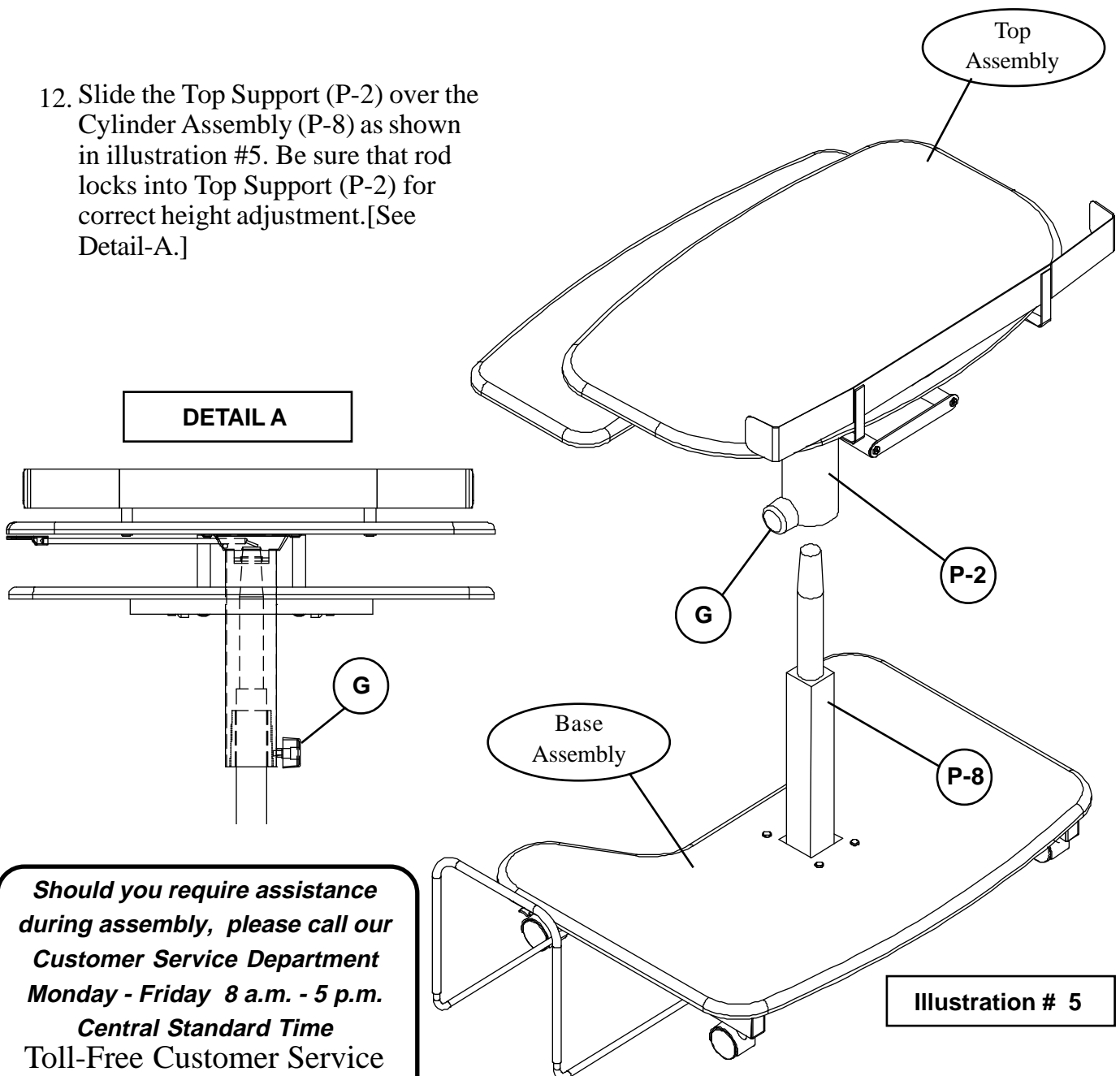

***Should you require assistance during assembly, please call our Customer Service Department Monday - Friday 8 a.m. - 5 p.m. Central Standard Time Toll-Free Customer Service 1-800-749-2258***

**Illustration # 5**

# #45972 HI-LO-3

## Adjustable Pneumatic Workstation

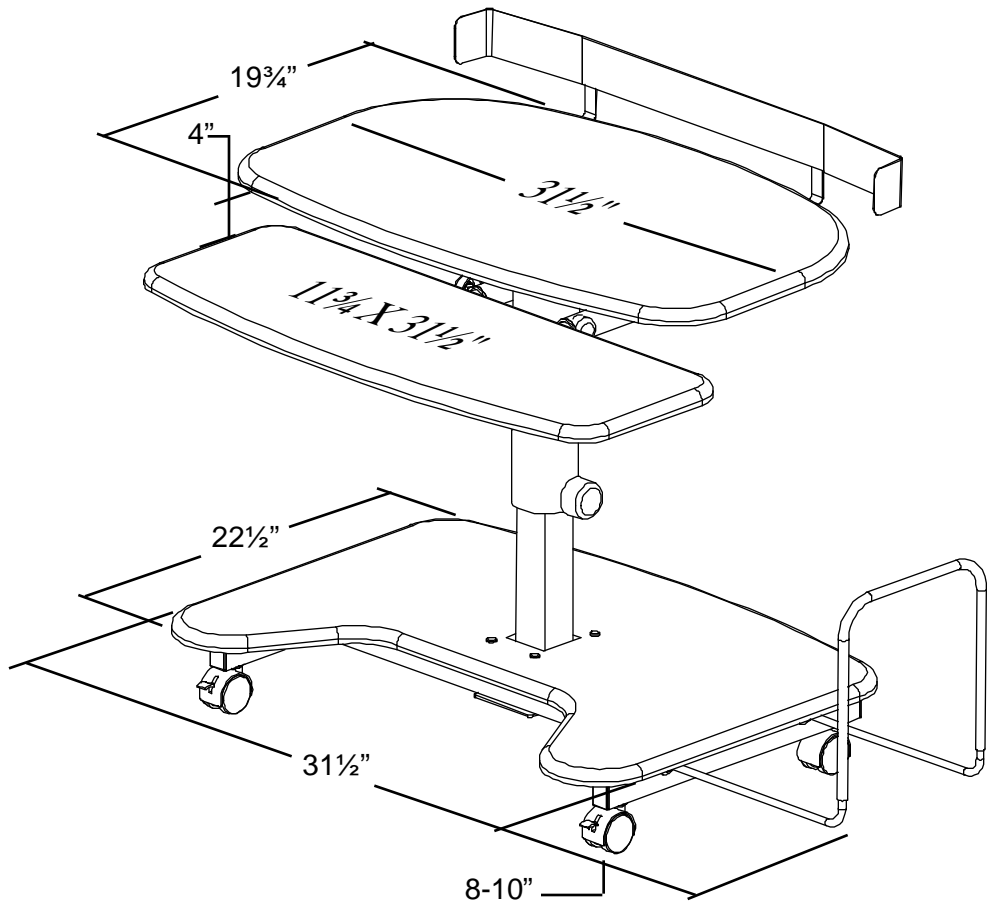

Shipping Information  
4.0 Cubic Feet  
56 lbs.

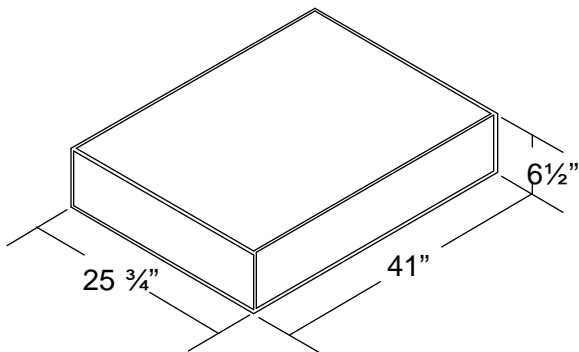

Height adjustable with infinite positions ranging from 20<sup>3</sup>/<sub>4</sub>" to 28<sup>1</sup>/<sub>2</sub>" for Keyboard shelf and 24<sup>3</sup>/<sub>4</sub>" to 32<sup>1</sup>/<sub>2</sub>" for Monitor Shelf.

Keyboard Shelf pulls out for individual user Comfort.

Includes 2" Casters for mobility.

Available in Mahogany Laminate or Teak Laminate w/Black Frame.

Ships UPS.

01/20/05